

Information documents are not authoritative. Information documents are for information purposes only and are intended to provide guidance. In the event of any discrepancy between an information document and any authoritative document¹ in effect, the authoritative document governs.

1 Purpose

This information document relates to the following authoritative document:

- Section 502.5 of the ISO rules, *Generating Unit Technical Requirements* (“Section 502.5”).

The purpose of this information document is to provide each legal owner of a generating unit with clarity regarding generating unit technical requirements.

2 Background

Section 502.5 sets out minimum technical requirements for the legal owner of any synchronous generating unit that is connected or intends to connect to the transmission system. This includes:

- (a) a new synchronous generating unit;
- (b) an existing synchronous generating unit; and
- (c) an existing synchronous generating unit that is undergoing a modification to any component comprising the generating unit.

3 Maximum Authorized Real Power and Reactive Power

The maximum authorized real power may not be the nameplate real power output² value of the generator stator, as many parameters can influence this value, including:

- (a) the maximum real power capability of the combination of the generator stator, electrical rotor, and exciter ratings, which allows the generating unit to meet the reactive power requirements of subsection 5 of Section 502.5;
- (b) the turbine capability under optimum conditions, which may be significantly different than the nameplate, in particular, for gas turbines or generating units that have been updated; and
- (c) the transformer capability, in MVA, which may limit the real power output of the generating unit and the reactive power output to the transmission system; or any other miscellaneous items, such as the coupling from the turbine to the generator.

3.1 Power relationships

Subsections 4(1) and 4(2) of Section 502.5 set out maximum authorized real power requirements for each legal owner of a generating unit.

The power triangle, illustrated in Figure 1 below, shows the relationship between real power (MW), reactive power (MVar), and apparent power (MVA).

¹ “Authoritative document” is the general name given by the AESO to categories of documents made by the AESO under the authority of the *Electric Utilities Act* and associated regulations, and that contain binding legal requirements for either market participants or the AESO, or both. Authoritative documents include: the ISO rules, the reliability standards, and the ISO tariff.

² The nameplate real power output for a generating unit is the manufacturer’s values based on factory acceptance tests.

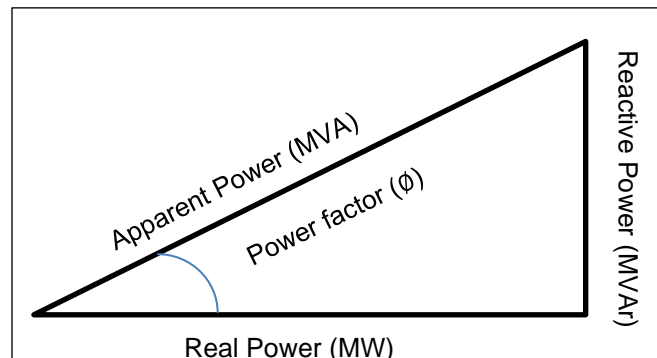

Figure 1: Power Triangle

It follows that the relationship between apparent power, real power, and reactive power can be described through the Equations 1 to 4.

- (1) $\text{Apparent Power (MVA)}^2 = \text{Real Power (MW)}^2 + \text{Reactive Power (MVAR)}^2$
- (2) $\text{Real Power (MW)} = \text{Apparent Power (MVA)} \times \text{Cos}\phi$
- (3) $\text{Reactive Power (MVAR)} = \text{Apparent Power (MVA)} \times \text{Sin}\phi$
- (4) $\text{Apparent Power (MVA)} = \text{Real Power (MW)} \div \text{power factor}$

3.2 Reactive Power Requirements

The reactive power requirements for each legal owner of a generating unit are set out in subsection 5 of Section 502.5. Depending on the maximum authorized real power value the legal owner chooses, Equations 5 and 6 below may be used to calculate the reactive power requirements set out in subsection 5(3)(a) and 5(3)(b), respectively.

- (5) $\text{Lagging reactive power capability (over-excited)} = \text{MARP} * \text{Tan} (\text{Cos}^{-1}(0.90))$
- (6) $\text{Leading reactive power capability (under-excited)} = - \{\text{MARP} * \text{Tan} (\text{Cos}^{-1}(0.95))\}$

where:

MARP = maximum authorized real power
 Power factor, over-excited = 0.9
 Power factor, under-excited = 0.95

3.3 Examples

In some cases, the maximum authorized real power of a generating unit will be the same as the real power output nameplate rating, in other cases it may differ from the real power output nameplate rating. The examples below have been provided to clarify subsections 4(1) and 4(2) of Section 502.5.

(a) Example 1

Example 1 illustrates the relationship between the maximum authorized real power, reactive power requirements, and the apparent power rating using Equations (5), (6), and (4), respectively.

If the maximum authorized real power = 100 MW, then

Lagging reactive power requirement (over-excited) = $100 \text{ MW} * \text{Tan} (\text{Cos}^{-1}(0.90)) = 48.4 \text{ MVAR}$;

Leading reactive power requirement (under-excited) = $- \{100 \text{ MW} * \text{Tan} (\text{Cos}^{-1}(0.95))\} = -32.9 \text{ MVAR}$; and

Apparent Power (MVA) rating = Real Power (MW) ÷ power factor = 100 MW ÷ 0.9 = 111.1 MVA

(b) Example 2

In Example 2, a generating unit has a nameplate apparent power rating of 100 MVA and a power factor of 0.85. In this example, the real power rated output would be calculated, using Equation 4, as follows:

$$\text{Real Power (MW)} = \text{Apparent Power (MVA)} \times \text{power factor} = 100 \text{ MVA} \times 0.85 = 85 \text{ MW}$$

Subsection 5(3)(a) of Section 502.5 requires the generating unit have a capability to operate with a 0.9 power factor, over-excited. Using Equation 4, this could result in the Example 2 generating unit operating at 90 MW to meet subsection 5(3) of Section 502.5.

(c) Example 3

In Example 3, a generating unit is equipped with a gas turbine with a nameplate rating of 100 MVA at 0.90 power factor and the performance profile shown in Figure 2. For the Example 3 generating unit, the real power output would be calculated as follows using Equation 4:

$$\text{Real Power (MW)} = \text{Apparent Power (MVA)} \times \text{power factor} = 100 \text{ MVA} \times 0.9 = 90 \text{ MW}$$

However, the nameplate rating of a gas turbine is specific to ambient temperature and pressure. Colder ambient temperatures allow gas turbines to operate at values significantly above the nameplate values, as illustrated in Figure 2³ below. Depending on the generating unit cooling and automatic voltage regulator supplied with the generating unit, the generating unit may be able to achieve real power output greater than 100 MW when the ambient temperature is less than -18°C and may still be in compliance with the requirements set out in subsections 4(1), 4(2), and 5(3) of Section 502.5.

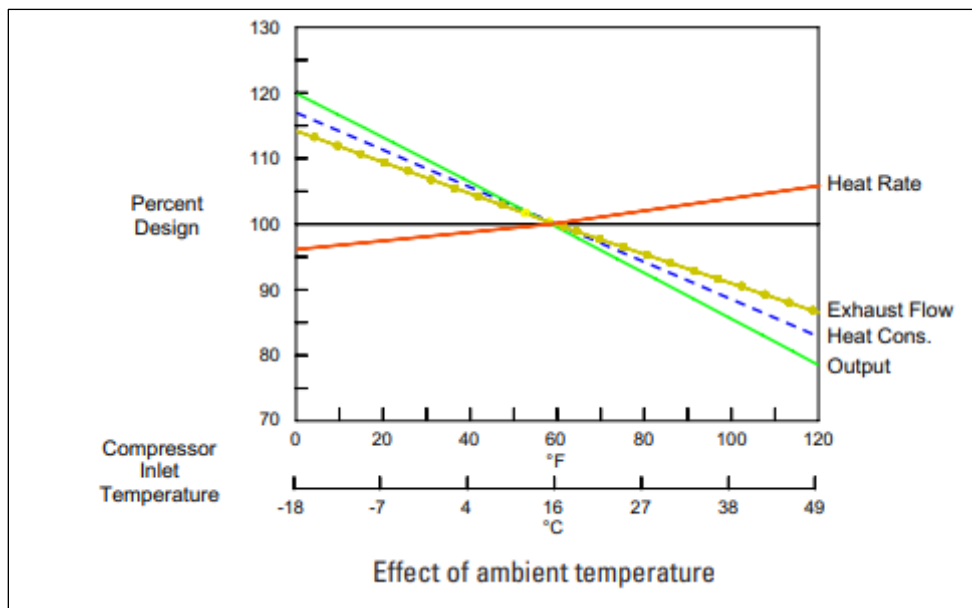

Figure 2: Effect of ambient temperature

³ GE Power System, *GE gas Turbine Performance Characteristics*, Fran J. Brooks, available on www.ge.com.

3.4 Under- and Over-Excitation Limiter Settings

The AESO recommends that the legal owner of a generating unit consider the under- and over-excitation limiter settings when determining the maximum authorized real power. If the limiters cause the reactive power capability of the generating unit to be reduced such that subsection 5(3) of Section 502.5 cannot be met, then the AESO recommends that the legal owner reduce the maximum authorized real power accordingly.

3.5 Reactive power compensation

Pursuant to subsection 5(7), if the legal owner of a generating unit determines that it will be unable to meet the requirements set out in subsection 5(3), the legal owner of a generating unit may apply to the AESO to mitigate this through the use of external dynamic reactive power resource, such as a static VAR compensator or a synchronous condenser as soon as practicable once the generating unit connection project has entered the AESO Connection Process.

4 Voltage Ride-Through for Existing Generating Units

Pursuant to subsection 6 of Section 502.5, the legal owner of a generating unit is expected to consider the voltage level at the point of connection when determining the voltage ride-through capability for an existing generating unit. That voltage level consideration would be used as the 1.0 p.u. voltage for the voltage ride-through requirements. In Alberta, voltages of the transmission system vary considerably throughout the province and may also vary from the nominal voltages. For information about voltage limit of key substations, see Appendix 1 of information document ID# 2010-007RS, *General Operating Practices - Voltage Control*.⁴

Pursuant to subsection 6(3) of Section 502.5, the legal owner of a generating unit is required to operate continuously at voltage values determined under subsection 6(2) of Section 502.5, which may include normal, warning, and emergency voltage limits. The length of time that the transmission system operates at the higher limits is dependent on the nature of the contingency. The AESO considers a generator trip to have occurred when the generating unit breaker or the transmission system breaker opens based on a trip signal from the protection system of the generating unit. This protection may be electrical, mechanical, or process based. The AESO recommends that a legal owner of a generating unit consider the following factors when determining the voltage ride-through capability:

- (a) protection functions picking-up, timing out, and resulting in the tripping of one or more generating units or critical devices;
- (b) contactors dropping out causing a critical device to go off-line;
- (c) critical motors stalling; and
- (d) other conditions that may result in the generating unit going off-line as a direct result of the voltage disturbance.

In addition, as set out in subsections 6(3)(b) of Section 502.5, a legal owner of a generating unit is expected to consider the same factors for the post-transient voltage deviations.

As set out in subsection 6(3)(b), Appendix 1 of Section 502.5 sets out the timing requirements. In Appendix 1, the solid line defines the transmission system voltages for which the existing generating unit is required to ride-through, and the shaded area defines the time frame that the generating units and auxiliary systems are required stay on-line for.

Subsection 6(3)(c) of Section 502.5 refers to normal clearing times for a 3-phase fault. The AESO recommends that the legal owner of the generating unit contact the legal owner of the transmission facility, to which its generating unit is connecting, for information about the fault clearing time values for

⁴ Available on the AESO website.

the transmission facility.

The legal owner is expected to use the standard fault clearing times shown in Table 1 for new transmission facilities or when the actual clearing times are not available for the existing transmission facilities. Double line-to-ground faults are applied for the Category C5 events with normal clearing times.

Table 1: Fault Clearing Times for Transmission Facilities by Nominal Voltage

Nominal Voltage kV	Near End Cycles	Far End Cycles
500	4	5
240	5	6
144/138 (with telecommunications)	6	8
144/138 (without telecommunications)	6	30

In some cases, the normal fault clearing times are greater or less than the typical values shown in subsection 35(5) of Section 502.3 of the ISO rules, *Interconnected Electric System Protection Requirements*.

5 Voltage Ride-Through for New Generating Units

Subsection 7(2), 7(3), and Appendix 2 of Section 502.5, sets out voltage ride-through requirements for new generating units. The concept of how the voltage ride-through is determined is similar to the approach described in section 4 of this information document above for existing generating units.

6 Voltage Regulation

Pursuant to subsection 8 of Section 502.5, the AESO uses the term “point of control” in relation to automatic voltage regulators to describe the electrical point controlled by the automatic voltage regulator. Automatic voltage regulators commonly have control features that allow the point of control to be moved away from voltage input to the automatic voltage regulator. This control feature is commonly referred to as reactive current compensation or, in some cases, voltage droop.

Generally, this is the same point as the voltage input to automatic voltage regulator which is typically the stator winding terminals of the generating unit. Figures 3 through Figure 5 have been provided below as examples of various points of control to assist the legal owner of a generating unit interpret the requirements as set out in subsections 8(4), 8(5), and 8(6) of Section 502.5.

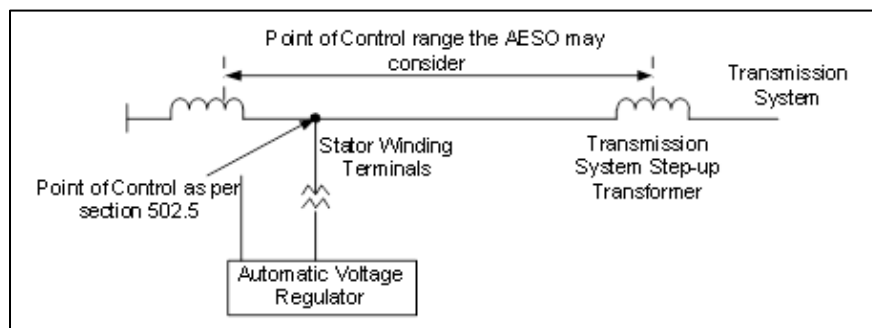

Figure 3: Point of Control, Simplified Impedance Diagram of a Single Generating Unit

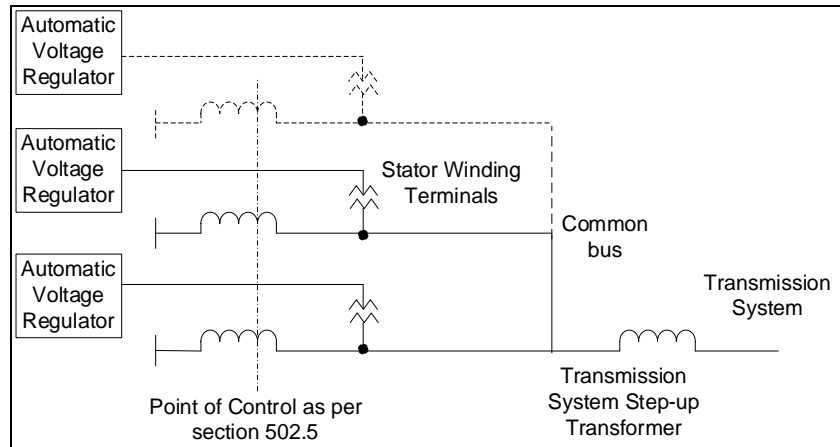

Figure 4: Point of Control, Simplified Impedance Diagram of Multiple Generating Units on a Common Bus

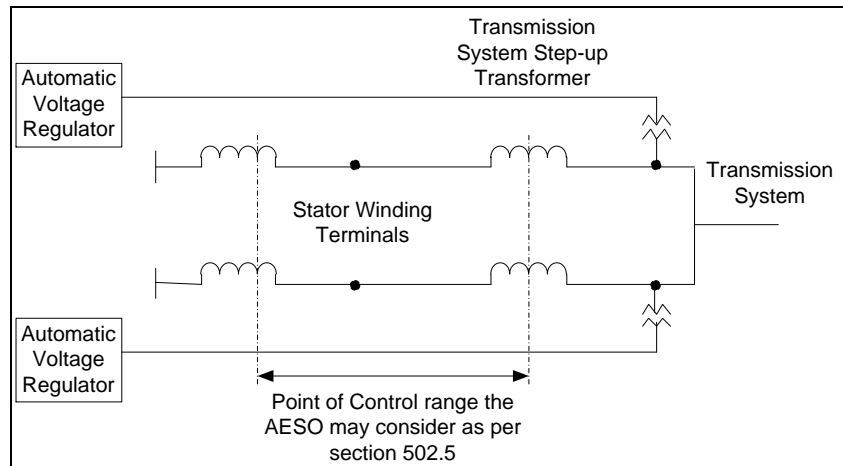

Figure 5: Point of Control, Simplified Impedance Diagram of Multiple Generating Units with a Single Measurement Point

7 Governor System Requirements

Subsection 9 of Section 502.5 sets out governor system frequency and droop control requirements. These requirements are in place to assist the AESO in maintaining the interconnected electric system frequency at 60 Hz during:

- (a) normal system operation that includes fluctuation in load;
- (b) disturbances; and
- (c) islanded operation of a generating unit from the larger transmission system along with some load external to the generating unit. In some cases, an islanded operation may include more than one generating unit.

Note that, during any of the above-mentioned conditions, the generating unit may trip off-line if the frequency goes outside of the boundaries illustrated in Appendix 3 of Section 502.5. For additional guidance on how droop control, as well as generator primary frequency response works, the AESO provides the following information:

- (a) subsection 9(1)(b) of Section 502.5 sets out the droop setting requirements which are based on

the maximum operating range of the generating unit. A governor system with a droop setting of 3% is expected to be more responsive to interconnected electric system frequency excursions compared to a governor system with a droop value selection of 4%;

- (b) subsection 9(1)(c) of Section 502.5 sets out deadband frequency requirements. The AESO expects that the combined intentional and non-intentional deadband of the governor system is to not exceed the requirement set out in subsection 9(1)(c) of Section 502.5. The governor system with a zero deadband will initiate its action faster compared to a governor system with a 36 mHz deadband;
- (c) the AESO expects the governor to have a sample rate of less than or equal to 20 samples per second;
- (d) the AESO expects the governor to have a resolution of greater than or equal to 0.004 Hz; and
- (e) the AESO expects the generating unit to be capable of providing frequency response (ΔMW) to both over frequency and under frequency system events using Equations 7 and 8 below:

$$(7) \Delta MW = \text{unit}_{MW \text{ Capability}} \times \frac{60-f-f_{db}}{60 \cdot \text{droop}}, \text{ when } f < 60\text{Hz} - \text{db}$$

$$(8) \Delta MW = \text{unit}_{MW \text{ Capability}} \times \frac{60-f+f_{db}}{60 \cdot \text{droop}}, \text{ when } f > 60\text{Hz} + \text{db}$$

Where:

$\text{Unit}_{MW \text{ Capability}}$ = maximum authorized real power value of the generating unit, in case of the gas turbine units and maximum authorized real power will be based on the optimum generation capability based on the ambient temperature and other operating parameters;

f_{db} = deadband frequency; and

f = actual frequency.

The AESO expects that the generating unit provide a sustained primary frequency response to system frequency excursion events. The sustained response can be defined as an increase or decrease in the output after the frequency deviates outside the governor deadband during a frequency excursion event with a frequency response that is proportional to the ongoing frequency deviation beyond the governor deadband and continuing until the frequency returns to within the governor deadband (60 +/- 0.036 Hz). For additional guidance on sustained primary frequency response, the AESO provides the following information:

- (a) the AESO expects the frequency response (ΔMW) to have no time delays, ramp characteristics, or other control settings that prevent the generating unit spinning reserve resource from providing an immediate, automatic, and sustained response to frequency deviations beyond deadband;
- (b) the AESO expects related outer-loop controls within the distributed control system, as well as other applicable generating units or plant controls, to be set to avoid early withdrawal of primary frequency response or interference with the primary frequency response;
- (c) in the case where a generator is participating in the regulating reserve, the AESO expects the automatic generation control signals to be properly coordinated at the generating unit level so that they do not create counteractive actions when the generating unit is providing primary frequency response; and
- (d) the AESO does not expect generating units that are base loaded, i.e., operating at full load, to respond to low frequency excursions but, with the governors free to react, these generating units should respond to high frequency excursions and decrease output accordingly. This includes the steam turbine generating unit portion of a combined cycle or co-generation generating facilities.

The NERC has identified a primary frequency response issue from generating units during system over- and under-frequency events and has conducted extensive stakeholder consultations in the different jurisdictions across the United States. The NERC provides industry advisory guidance on this issue and

other related documents on its website.

The AESO endorses these NERC supplementary references⁵ and encourages the legal owner of a generating unit to review the documents to get a better understanding of the expected frequency response from its generating unit.

8 Transmission System Step-Up Transformer

The AESO provides the following additional guidance on transformer sizing:

- (a) in order to meet the requirements of subsection 11(1) of Section 502.5, the AESO expects the thermal capability of the transformer to be equal to the apparent power capability of the generating unit. This is illustrated in the example provided in Figure 6 of this information document below.
- (b) the thermal capability is not necessarily the nameplate rating of the transformer. The legal owner of a generating unit may submit a request for a variance under Section 103.14 of the ISO rules, *Waivers and Variances*, to use a higher apparent power capability than the nameplate rating of the transformer. The AESO expects the legal owner of a generating unit to submit the basis for the higher capability with their request, in a report that is stamped by a professional engineer registered in Alberta.

⁵ NERC, *Reliability Guideline Application Guide for Modeling Turbine Governor and Active Power-Frequency Controls in Interconnection-Wide Stability Studies*, dated June 2019, Available at www.nerc.com.

NERC, *Reliability Guideline Application Guide for Modeling Turbine Governor and Active Power-Frequency Controls in Interconnection-Wide Stability Studies*, dated June 2019, Available at www.nerc.com.

NERC, *Industry Advisory Generator Governor Frequency Response Initial Distribution*, dated February 5, 2015, Available at www.nerc.com.

NERC, *Primary Frequency Response – Natural Gas/Combined Cycle Webinar*, dated November 13, 2018, Available at www.nerc.com.

NERC, *Primary Frequency Response – Steam Generation Webinar*, dated November 13, 2018, Available at www.nerc.com.

NERC, *Reliability Guideline Primary Frequency Control May 2019 Approved by the Operating Committee*, dated June 4, 2019, Available at www.nerc.com.

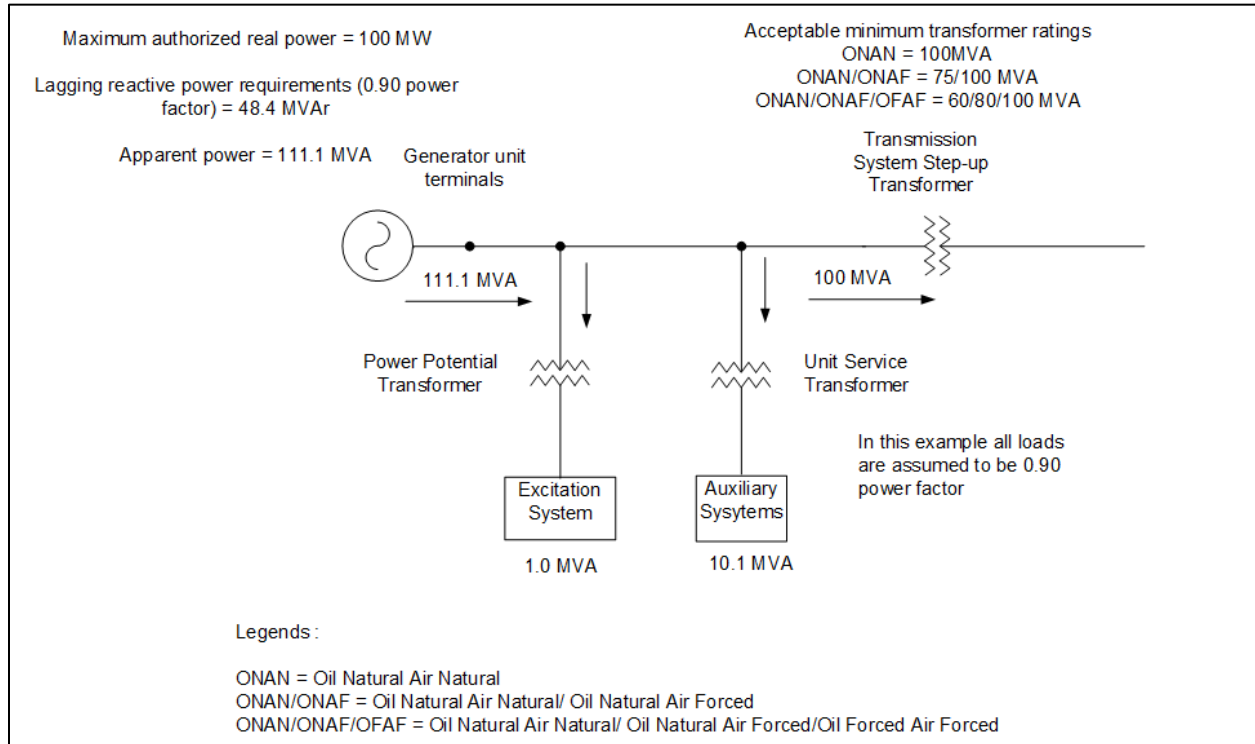

Figure 6: Transmission System Step-Up Transformer Sizing Example

9 Auxiliary Systems

Subsection 12 of Section 502.5 contains auxiliary system requirements for the legal owner of a generating unit. The AESO considers all components, both external to and within the generating unit, that are crucial to the normal operation of the facility to be part of the auxiliary systems. This would include systems like fuel and fuel handling system, cooling water system, switch yards, low-pressure gas compression system, instrument air system, and fire protection system. The AESO expects the legal owner to design the power generation facility in a way that a single component failure of the auxiliary system does not lead to the tripping of multiple generating units at the facility.

10 Synchrophasor Measurement System Requirements

Subsection 18 of Section 502.5 sets out generating unit synchrophasor measurement system requirements. The technical requirements specific to the synchrophasor measurement system are set out in Section 502.9 of the ISO rules, *Synchrophasor Measurement Unit Technical Requirements* ("Section 502.9"). The legal owner is encouraged to review Section 502.5 in conjunction with Section 502.9.

The AESO provides the following guidance to the legal owner regarding the installation of a synchrophasor measurement system when replacing protections systems:

- (a) for new generating units, pursuant to subsection 2 of Section 502.5, the AESO provides a functional specification, which specifies the sample rate and other required configuration parameters for synchrophasor measurement systems. Most modern generating units are installed with multi-function relays. Replacement of one of these relays on a planned basis triggers the requirement for a synchrophasor measurement system pursuant to subsection 18(1) of Section 502.5. It is the AESO's opinion that most modern multi-function relays have synchrophasor measurement system capabilities which meet the requirements of Section 502.5; and
- (b) for existing generating units with protection systems comprised of single element relays, it is the AESO's opinion that unless the legal owner is replacing a single element due to failure, then the

legal owner would generally install a multi-function relay. Such a change triggers the requirement for a synchrophasor measurement device pursuant to subsection 18(1) of Section 502.5. The AESO also notes that many modern single element relays also have synchrophasor measurement system capability. In the case of an existing generating unit that undergoes a modification to replace the protective relays without a functional specification document the AESO issued, the AESO recommends using a sample rate that is greater than or equal to 30 samples per second.

Revision History

Posting Date	Description of Changes
2021-11-12	Added new content to clarify subsections 2, 4, 5, 6, 7, 8, 9, 11, and Appendix 1 of Section 502.5, and updated content related to subsection 18(1) of Section 502.5.
2020-06-22	Initial version