

AESO FUNCTIONAL SPECIFICATION

Functional Specification

North Lethbridge 370S Substation Upgrade

AESO Project Number: P2123

Issued to:

AltaLink Management Ltd., (as the **legal owner** of a **transmission facility**), and to
 FortisAlberta Inc. (as the **market participant**)

Date: September 21, 2020

Version: V2

Classification: Public



	Name	Signature	Date
Author	Yaoyu Huang, P. Eng.	<i>Chylylu</i>	September 21, 2020
Checked & Approved – Manager, Project Engineering	Changling Luo, P. Eng.	<i>Chylylu</i>	September 21, 2020

APEGA
 Permit-to-Practice *Chylylu*
 P-8200 *September 21, 2020*

Functional Specification Revision History

Revision	Description of Revision	By	Date
V1D1	<ul style="list-style-type: none">• For internal Comments	Yaoyu Huang	January 7, 2019
V1D2	<ul style="list-style-type: none">• For external Comments	Yaoyu Huang	January 23, 2019
V1	<ul style="list-style-type: none">• For Issuance	Yaoyu Huang	March 27, 2019
V2D1	<ul style="list-style-type: none">• Project title update• ISD update• ISO rule section update• SLD 25 kV connection update• For Comments	Yaoyu Huang	September 10, 2020
V2	<ul style="list-style-type: none">• For Issuance	Yaoyu Huang	September 21, 2020

TABLE OF CONTENTS

1	PURPOSE	4
2	INTERPRETATION AND VARIANCES.....	4
3	PROJECT OVERVIEW.....	5
4	FORECAST OF FUTURE DEVELOPMENT IN THE PROJECT AREA 5	
5	SCOPE OF WORK	5
	5.1 General.....	5
	5.2 Compliance with AESO Authoritative Documents	6
	5.3 Modelling Data Requirements	6
	5.4 Substation Equipment Specifications	6
	5.5 Specific Scope of Work for the Legal Owner of a Transmission Facility	7
	5.6 Scope of Work for the Market Participant	9
6	TRANSMISSION SYSTEM OPERATING CHARACTERISTICS.....	9
	6.1 Short Circuit Current Levels.....	9
	6.2 Voltage Levels	11
	6.3 Insulation Levels.....	12
	6.4 Remedial Action Scheme (RAS).....	12
7	APPENDICES	13
	7.1 Area Transmission System – Existing with Proposed Development Area	13
	7.2 Single Line Drawing.....	14
	7.2.1 Single Line Drawing – Existing North Lethbridge 370S Substation	14
	7.2.2 Single Line Drawing – North Lethbridge 370S Substation – Proposed.....	15
	7.3 SCADA Requirements.....	16
	7.4 Static Data Requirements.....	17

1 PURPOSE

(1) The purpose of this document (the “Functional Specification”) is to set out the technical specifications, requirements and approved variances related to the design, construction, development and commissioning of certain new or modified facilities (the “Project”) that have been proposed for or are related to a physical facilities connection with the Alberta **interconnected electric system** (AIES). This Functional Specification is issued by the Alberta Electric System Operator (AESO) to:

- (i) AltaLink Management Ltd. In its capacity as general partner of AltaLink, L.P., (AltaLink), as the **legal owner** of a **transmission facility** described in the Functional Specification.
- (ii) FortisAlberta Inc., (Fortis), as the **market participant** that has submitted a request for **system access service**.

(2) This Functional Specification is issued for the Project only. The **legal owner** of a **transmission facility** and the **market participant** must comply with the Functional Specification provisions.

(3) The AESO is not responsible for any facilities designed by or for any third party, or installed on a third party’s behalf, to accomplish the connection of the Project facilities.

(4) This Functional Specification includes:

- (i) certain specific engineering, technical and functional requirements for the Project;
- (ii) the requirements to comply with **ISO rules**, including Operating Policies & Procedures (OPPs), **reliability standards**, technical standards, and **ISO tariff** provisions (collectively called the “Authoritative Documents”);
- (iii) the electrical system environment in which the connecting facilities must be designed and operated; and
- (iv) any approved variances from requirements set out in any applicable AESO Authoritative Documents.

2 INTERPRETATION AND VARIANCES

(1) Subject to subsection (2), any revision or variance to any of the Functional Specification provisions by the **legal owner** of a **transmission facility** or the **market participant** is prohibited.

(2) The **legal owner** of a **transmission facility** or the **market participant** may make application, jointly or individually, in writing to the AESO requesting a variance to this Functional Specification, and the AESO may in writing approve of the variance after the AESO has completed an analysis of the implications to the AIES with respect to the requested variance.

(3) Words or phrases appearing in bold have the meanings set out in the AESO *Consolidated Authoritative Document Glossary*.

3 PROJECT OVERVIEW

The **market participant** submitted a request for **system access service** to the AESO to improve the reliability of electricity services in the City of Lethbridge area located in the AESO transmission planning area of Lethbridge (Area 54).

The **market participant's** request can be met by the following transmission development:

- Modify the existing North Lethbridge 370S substation, including adding a 138 kV circuit breaker.
- Add or modify associated equipment as required for the above transmission developments.

The **market participant's** request does not include existing Rate DTS, *Demand Transmission Service*, contract capacity change.

The scheduled in-service date (ISD) for this Project is November 1, 2021.

4 FORECAST OF FUTURE DEVELOPMENT IN THE PROJECT AREA

Proposed long term developments in the Lethbridge (Area 54) are described in the AESO 2020 Long-term Transmission Plan. Please refer to the AESO's website (www.aeso.ca) for more details of the long term transmission developments in the area.

5 SCOPE OF WORK

5.1 General

The **legal owner** of a **transmission facility** and the **market participant** must:

- (1) complete all engineering, design, land or land-use acquisition, siting, public consultation, applicable regulatory approvals and permits, material procurement, construction, commissioning, and associated permitting requirements for the Project facilities.
- (2) coordinate with each other, as required, on all Project facility design details, including protection and control, grounding, insulation, **point of connection**, and site layout with proper consideration of maintenance coordination.
- (3) develop joint operating procedures and any connection agreements, as required, such that all connecting **transmission facilities** will operate safely and reliably.
- (4) deliver to the AESO all final design and as-built Project facility information and records in the format and content required by the AESO, to enable the AESO to update and maintain its transmission technical records and system models.
- (5) submit the Project information and records referred to in subsection (4) above, under the professional stamp and signature of a registered professional engineer in Alberta who assumes responsibility for the preparation and accuracy of the content of the information and records.
- (6) mutually agree on each party's roles and responsibilities regarding inspection of all facilities of the Project prior to energization of the facilities.

(7) ensure prior to energization of any or all of their respective Project facilities, that the facilities to be energized have been inspected by qualified personnel, so that the facilities are declared to be:

- (a) safe for operation; and
- (b) in compliance with this Functional Specification and any Authoritative Documents for which the Project must comply.

(8) Not energize any Project facilities until an energization authorization has been issued by the AESO in accordance with the **ISO rules**.

5.2 Compliance with AESO Authoritative Documents

The **legal owner** of a **transmission facility** and the **market participant** must comply with the Authoritative Documents provisions which are applicable to the Project and which must be satisfied and incorporated into the design, construction, commissioning and operation of the connecting facilities and other connection Project work, including but not limited to these provisions contained herein:

- AESO Operating Policies and Procedures
- Alberta Reliability Standards
- AESO Measurement System Standard Rev. 1 (dated September 18, 2007) ¹
- **ISO rules** including:
 - Section 502.3, *Interconnected Electric System Protection Requirements* (effective September 1, 2018);
 - Section 502.4, *Automated Dispatch and Messaging System and Voice Communication Systems Requirements* (effective March 27, 2015);
 - Section 502.8, *SCADA Technical and Operating Requirements* (effective September 1, 2018);

5.3 Modelling Data Requirements

All modelling data shall be provided as per the Information Document ID# 2010-001R Facility Modelling Data (issued on December 20, 2018), which relates to Section 502.15.

5.4 Substation Equipment Specifications

All new substation equipment³ must meet the following minimum specifications:

¹ The AESO considers this standard to remain in effect notwithstanding the statement in clause 1.5 of this standard. Efforts to revise the standard are currently underway.

- Temperature rating of -40°C for all outdoor equipment.
- Equipment maximum and minimum continuous voltage ratings as indicated in Table 5.
- Minimum continuous equipment current ratings as indicated in Table 1.
- Equipment maximum fault duty: 31.5 kA for 138 kV.

Table 1: Minimum Continuous Equipment Current Ratings (A)

Component ^{note 5}	138kV
Main Bus ^{Note 1}	1200
Cross Bus ^{Note 2,3}	600
Equipment or line terminal ^{Note 4}	600

Notes for Table 1:

- Note 1: Main bus includes all sections of ring bus scheme or single bus of simple bus or breaker and a half scheme except the portion of the bus connecting to a transformer.
- Note 2: Cross bus includes diameter sections of breaker and a half or breaker and a third schemes.
- Note 3: Cross bus can have higher minimum current rating based on bus configuration and equipment connectivity
- Note 4: Line terminal includes all equipment and conductor from the transmission line to the line breakers.
- Note 5: Current rating of the equipment below 69 kV within the substation shall be determined by the **legal owner** of a **transmission facility**, in consultation with **market participants**.

5.5 Specific Scope of Work for the Legal Owner of a Transmission Facility

(1) General Requirements

- Coordinate with the **market participant** to develop necessary connection agreements and joint operating procedures.
- Ensure project safety is appropriately managed from design through energization.
- Undertake all required grounding studies, testing and mitigation, as required, for electrical safety and any mitigation for electrical effects on communication systems.
- Complete insulation coordination studies and coordinate with the **market participant**, as required, to establish appropriate insulation levels.
- All site preparation, fencing, foundations, grounding, support structures, termination structures, duct work, cabling, bus work, station service, control building, protection, controls, SCADA equipment, etc., as required.
- Any lines from one bus terminal to remote bus terminal shall not have any terminal equipment that causes a derate of the minimum line capacity specified by the AESO.

³ Equipment includes such items as the power transformer, circuit breaker, capacitor bank, shunt reactor, high voltage current transformer, potential transformer, bus work, air break, and switchgear.

- The **legal owner** of a **transmission facility** shall provide access to the telecommunication system for communication services (SCADA, Operational Voice, Operational Data, and Synchrophasor Measurement Unit) if requested by the **market participant**, as required by the AESO for the operation of the AIES.

(2) Existing North Lethbridge 370S substation – See Appendix 7.2

Substation Major Equipment

- Add one (1) 138 kV circuit breaker and associated isolation switch.
- Add one (1) 25 kV circuit breaker and associated isolation switches.
- Motorize the existing 25 kV manual disconnect switches 370s5 and 370s45.
- Connect feeder 204LN and 455LW directly to 138/25 kV transformer T1 (TX 18421).
- Connect feeder 465LE to 138/25 kV transformer T4 (Tx18851).

Protection and Control Requirements

- Complete system protection coordination studies and coordinate with the **market participant** as required to establish settings appropriate for the facility additions and AIES operations.
- Install all the required protection and control equipment to accommodate the new facilities addition.
- Review, modify and/or upgrade the existing protections as required to accommodate the new connection and configuration.

SCADA Requirements

- Establish communications interface point such that SCADA data can be transmitted back to the AESO's System Coordination Center (SCC) and Backup Coordination Centre (BUCC).
- All new Remote Terminal Units (RTU) shall have Global Positioning System (GPS) for time synchronization.
- Implement control center data mapping and verification of SCADA information for the proposed transmission facility additions and modifications, and any associated changes required at other area substations as per Section 502.8 of the **ISO rules**. A complete listing of energy data requirements can be found in Appendices 7.3 and 7.4 of this document.

Telecommunication Requirements

- Install new or modify/upgrade the existing communication system as required and establish appropriate communication interface such that tele-protection, SCADA, operational voice, operational data and mobile radio requirements are met.

5.6 Scope of Work for the Market Participant

(1) General Requirements

- Coordinate with the **legal owner** of a **transmission facility** to develop necessary connection agreements and joint operating procedures.
- Undertake all required grounding studies, testing, and mitigation to ensure the connecting to transmission facilities are safe.
- Complete insulation coordination studies and coordinate with the **legal owner** of a **transmission facility**, as required to establish appropriate insulation levels.
- Ensure connection project safety is appropriately managed from design through energization.

6 TRANSMISSION SYSTEM OPERATING CHARACTERISTICS

The **legal owner** of a **transmission facility** and the **market participant** must ensure all facilities are capable of operating in the following electrical environment.

6.1 Short Circuit Current Levels

(1) The short circuit current levels set out in Tables 2, 3 and 4 have been derived by the AESO based on information provided by the **legal owner** of a **transmission facility**, any connecting **generating units**, and adjacent operating areas. Available fault current levels will continue to increase as generation, transmission, and system inter-ties are added to the AIES. The **legal owner** of a **transmission facility** and **market participant** must continue to review the fault levels and their equipment ratings for adequacy.

(2) Any future equipment upgrades or protection system setting changes required due to increasing fault levels are the responsibility of the **legal owner** of a **transmission facility** or the **market participant**, as applicable.

(3) The following assumptions were incorporated into the AESO short circuit current models:

- (i) All expected Alberta generation is dispatched.
- (ii) All transmission elements are in service.
- (iii) The proposed Project facility is connected as per this document.
- (iv) $V_{\text{base}} = V_{\text{bus}}$, $MVA_{\text{base}} = 100$

Table 2: Summary of Short-Circuit Current Levels – 2020⁴ WP Pre-Project

Substation Name and Number	Base Voltage (kV)	Pre-Fault Voltage (kV)	3- Φ Fault (kA)	Positive Sequence Thevenin Source Impedance (R1+jX1) (pu)	1- Φ Fault (kA)	Zero Sequence Thevenin Source Impedance (R0+jX0) (pu)
North Lethbridge 370S	240	250.8	10.3	0.0047135+0.0242134j	7.2	0.0143687+0.0550451j
North Lethbridge 370S	138	140.1	11.9	0.0076882+0.0353382j	9.2	0.0146689+0.0659661j
Chinook 181S	138	139.5	7.5	0.0167186+0.0540384j	5.2	0.0328273+0.1314062j
Coalbanks 111S	138	139.5	9.2	0.0123816+0.0445039j	6.7	0.0243402+0.0957458j
Uplands 241S	138	139.9	10.0	0.0090987+0.0417781j	7.3	0.0204786+0.0874871j
Macdonald 146S	138	139.9	10.0	0.0092797+0.0416706j	7.4	0.0202966+0.0869665j
Windy Flats 138S	240	248.7	11.7	0.0031892+0.0211378j	11.9	0.002759+0.0209028j
Picture Butte 120S	230	234.7	3.6	0.0057523+0.0717691j	2.9	0.0193725+0.1183076j
Travers 554S	240	254.2	8.0	0.0053561+0.0318766j	5.3	0.017734+0.0797556j

Table 3: Summary of Short-Circuit Current Levels – 2020⁵ WP Post-Project

Substation Name and Number	Base Voltage (kV)	Pre-Fault Voltage (kV)	3- Φ Fault (kA)	Positive Sequence Thevenin Source Impedance (R1+jX1) (pu)	1- Φ Fault (kA)	Zero Sequence Thevenin Source Impedance (R0+jX0) (pu)
North Lethbridge 370S	240	250.8	10.3	0.0047135+0.0242133j	7.2	0.014154+0.0543768j
North Lethbridge 370S	138	140.1	11.9	0.0076881+0.0353377j	9.3	0.0144396+0.0646884j
Chinook 181S	138	139.5	7.5	0.0167186+0.054038j	5.2	0.0326331+0.1302759j
Coalbanks 111S	138	139.5	9.2	0.0123815+0.0445034j	6.7	0.0241358+0.0945708j
Uplands 241S	138	139.9	10.0	0.0090987+0.0417776j	7.4	0.0202548+0.0862308j
Macdonald 146S	138	139.9	10.0	0.0092797+0.0416701j	7.4	0.020078+0.0857335j
Windy Flats 138S	240	248.7	11.7	0.0031892+0.0211378j	11.9	0.0027593+0.020877j
Picture Butte 120S	230	234.7	3.6	0.0057522+0.0717689j	3.0	0.0191964+0.1177123j
Travers 554S	240	254.2	8.0	0.0053561+0.0318766j	5.3	0.0175523+0.0792256j

⁴ The project ISD changes from 2020 to 2021, there is no major changes on the short circuit current levels.

⁵ The project ISD changes from 2020 to 2021, there is no major changes on the short circuit current levels.

Table 4: Summary of Short-Circuit Current Levels – 2028 WP Post-Project

Substation Name and Number	Base Voltage (kV)	Pre-Fault Voltage (kV)	3- Φ Fault (kA)	Positive Sequence Thevenin Source Impedance (R1+jX1) (pu) ⁵	1- Φ Fault (kA)	Zero Sequence Thevenin Source Impedance (R0+jX0) (pu) ⁵
North Lethbridge 370S	240	245.7	11.1	0.0041355+0.0220243j	9.9	0.0049851+0.0303335j
North Lethbridge 370S	138	140.2	12.1	0.0074927+0.0344249j	10.8	0.0066832+0.0481293j
Chinook 181S	138	139.3	7.6	0.0166713+0.0531588j	5.5	0.026058+0.1160842j
Coalbanks 111S	138	139.4	9.4	0.0122351+0.0435948j	7.4	0.0170477+0.0792279j
Uplands 241S	138	140.0	10.2	0.008916+0.0408624j	8.3	0.0126439+0.0699237j
Macdonald 146S	138	139.9	10.2	0.009104+0.0407562j	8.3	0.0126144+0.069703j
Windy Flats 138S	240	245.1	12.5	0.0028514+0.0195616j	12.6	0.0026535+0.0191916j
Picture Butte 120S	230	230.0	3.6	0.005239+0.0698976j	3.2	0.0112059+0.0959794j
Travers 554S	240	249.1	8.2	0.0049017+0.0302701j	7.0	0.006433+0.0464022j

6.2 Voltage Levels

Table 5 provides the normal planned operating voltage range in the area of the proposed facility.

Table 5: Planned Operating Range

Substation Name and Number	Nominal Voltage (kV)	Emergency Minimum Voltage (kV)	Desired Normal Minimum Voltage (kV)	Desired Normal Maximum Voltage (kV)	Emergency Maximum Voltage (kV)
North Lethbridge 370S	138	124	135	145	150

Notes:

1. The Desired Normal Operating Minimum and Desired Normal Operating Maximum are generally associated with Category A events and system normal.
2. The Emergency Minimum Voltage and Emergency Maximum Voltage are generally associated with Category B and C events and system abnormal.
3. The facilities must be capable of continuous operation at voltages up to and including the Emergency Maximum Voltage.

6.3 Insulation Levels

(1) Table 6 provides the minimum required basic insulation levels for the **transmission facilities**. Station equipment with lower insulation levels may be used provided that protection and coordination can be maintained with judicious insulation design and use of appropriate surge arresting equipment.

Table 6: Basic Insulation Levels (kV)

Nominal Voltage Classification (kV rms)	138
Station Post Insulators and Airbreaks	550
Circuit Breakers	650
Current and Potential Transformers	650
Transformer Windings (Protected by Surge Arresters)	550

6.4 Remedial Action Scheme (RAS)

The Engineering Study Report (ESR) for this Project has indicated that no new or modification to existing/planned RAS(s) or System Control Procedures (SCPs) were identified for this Project, under Category B contingency conditions, based on assumptions used in the study.

Prior to the ISD of the Project, additional operations planning studies will be performed to determine and/or confirm the required mitigation measures, RAS(s), or procedures, by taking into account other connection and system projects, as appropriate. System conditions under additional contingency categories will also be assessed as part of operations planning studies. This will ensure that appropriate mitigation will be in place prior to the ISD of the Project. The AESO will consult with the **legal owner** of a **transmission facility** and the **market participant** before specifying revised and/or new mitigation measures.

7 APPENDICES

7.1 Area Transmission System – Existing with Proposed Development Area

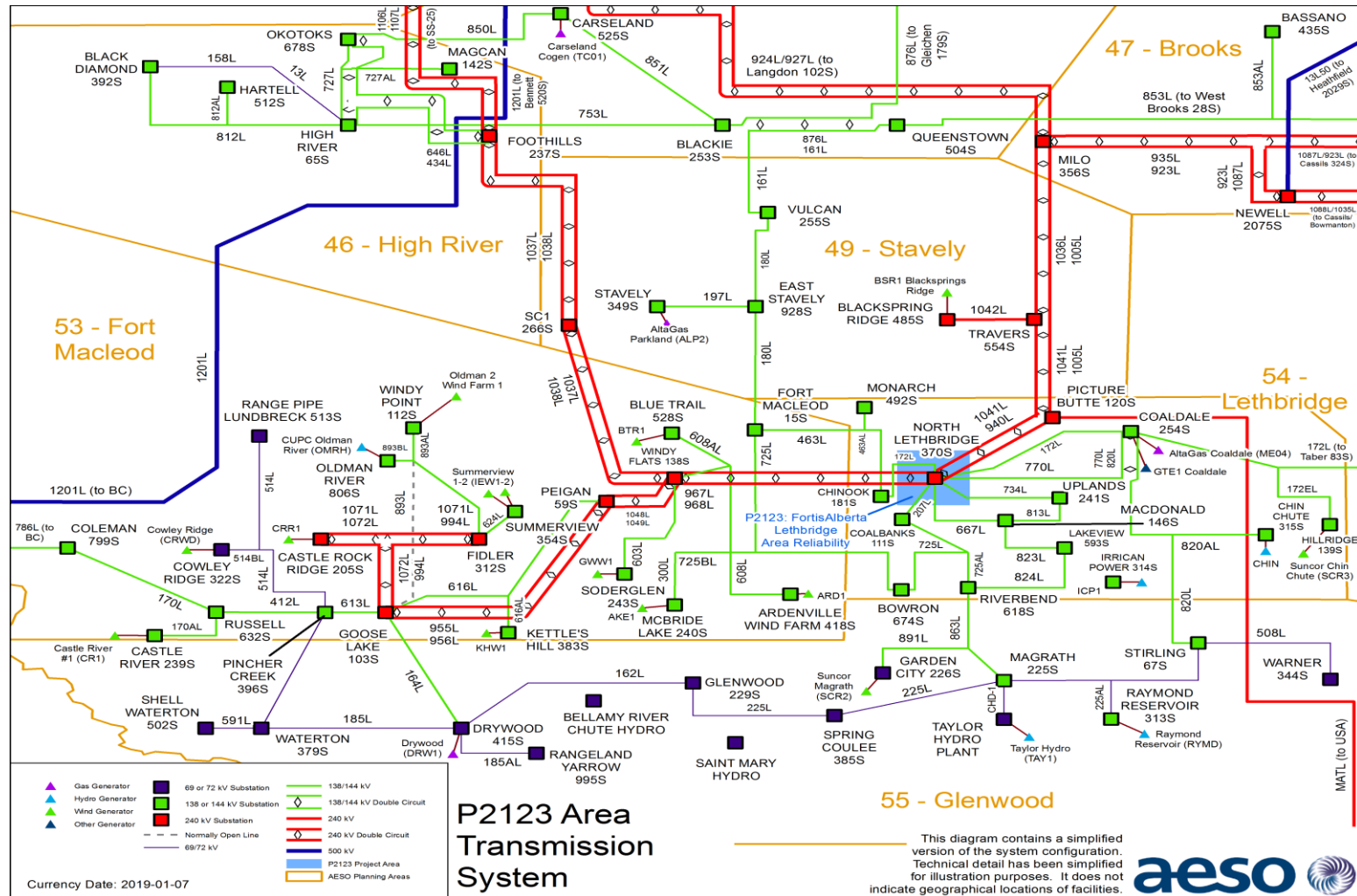

7.2 Single Line Drawing

7.2.1 Single Line Drawing – Existing North Lethbridge 370S Substation

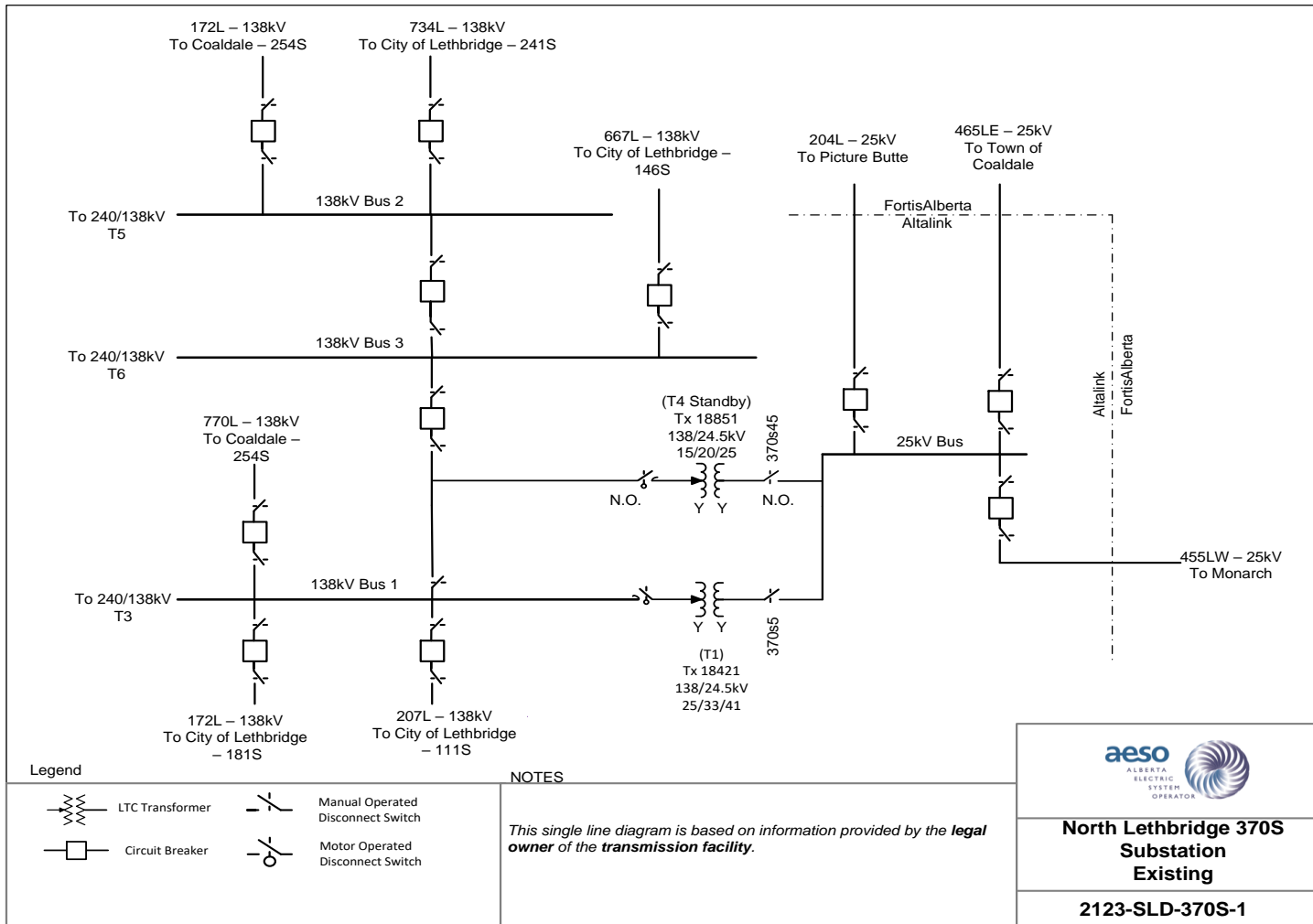

7.2.2 Single Line Drawing – North Lethbridge 370S Substation – Proposed

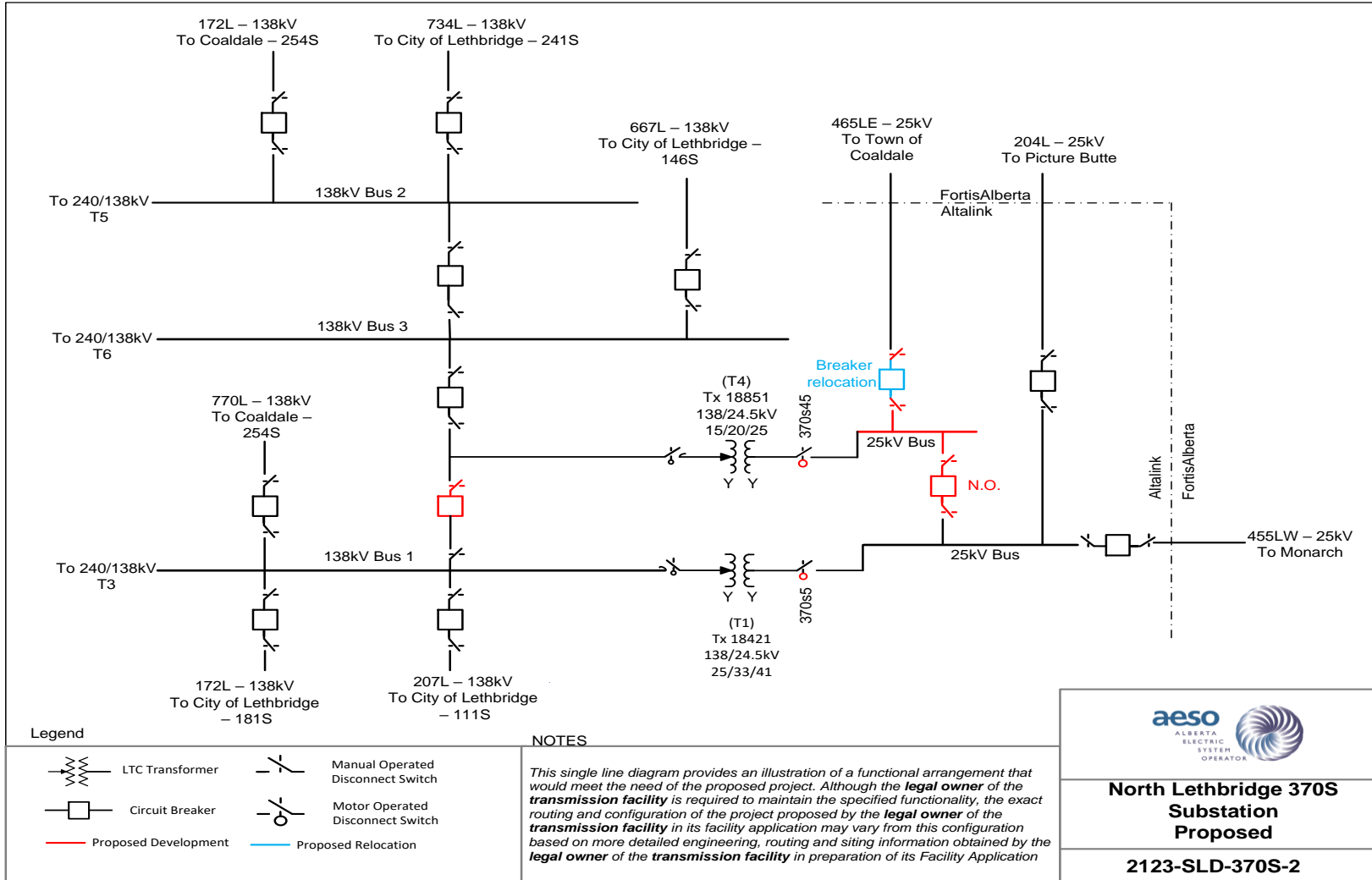

7.3 SCADA Requirements

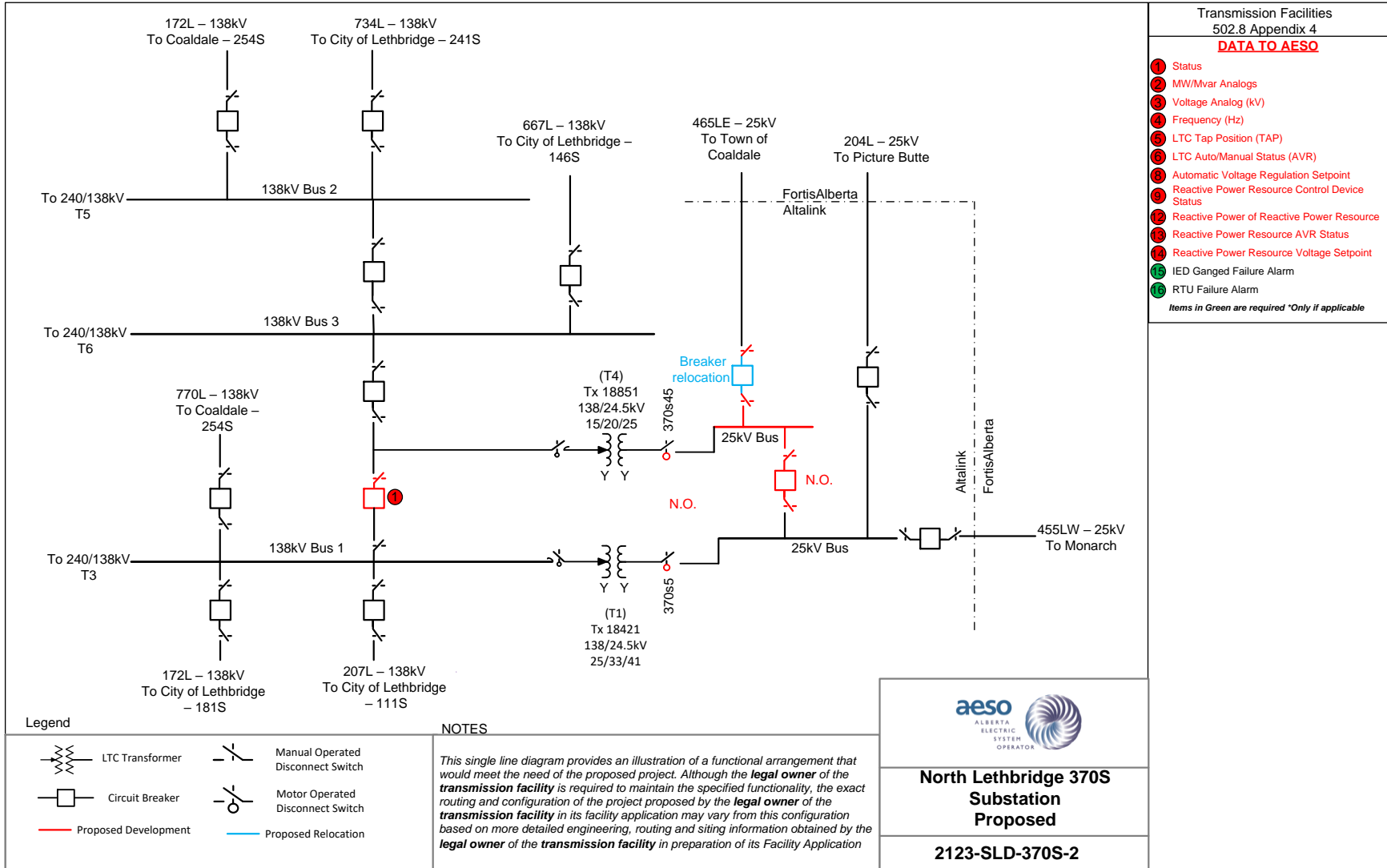

7.4 Static Data Requirements

Facility/Location	Device	Element	Indication	Max Latency	Notes
North Lethbridge 370S Substation	138kV CB1	CB1 associated with Bus 1	Status	15s	
Note	1. MW and MVar SCADA data shall be gathered independently of the revenue metering data				
	2. This list was prepared using the best available information. Final SCADA point will be determined based on the applicable SCADA Standard (502.8)				