

# **AESO FUNCTIONAL SPECIFICATION**

# Functional Specification

## North Lethbridge 370S Substation Transformer Contingency Project

AESO Project Number: P7073

**Issued to:**

AltaLink Management Ltd., (as the legal owner of a transmission facility)

**Date:** January 29, 2021

**Version:** V2

**Classification:** Public

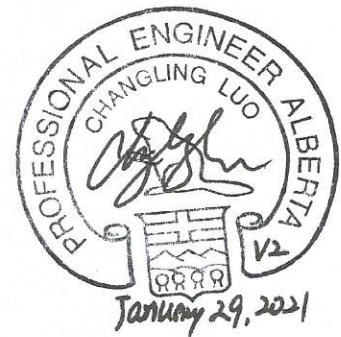

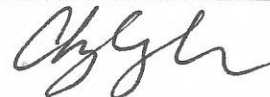
	Name	Signature	Date
Author	Yan Wang, P. Eng.		January 29, 2021
Checked & Approved – Manager, Project Engineering	Changling Luo, P. Eng.		January 29, 2021

**APEGA**  
 Permit-to-Practice   
 P-8200  
 January 29, 2021

### **Functional Specification Revision History**

<b>Revision</b>	<b>Description of Revision</b>	<b>By</b>	<b>Date</b>
V1D1	<ul style="list-style-type: none"><li>• For internal Comments</li></ul>	Yan Wang	November 13, 2020
V1D2	<ul style="list-style-type: none"><li>• For external Comments</li></ul>	Yan Wang	November 16, 2020
V1	<ul style="list-style-type: none"><li>• For Issuance</li></ul>	Yan Wang	December 1, 2020
V2	<ul style="list-style-type: none"><li>• Updated SLD</li></ul>	Yan Wang	January 29, 2021

## **TABLE OF CONTENTS**

1	PURPOSE .....	4
2	INTERPRETATION AND VARIANCES.....	4
3	PROJECT OVERVIEW.....	5
4	FORECAST OF FUTURE DEVELOPMENT IN THE PROJECT AREA	5
5	SCOPE OF WORK .....	5
	5.1 General.....	5
	5.2 Compliance with AESO Authoritative Documents .....	6
	5.3 Modelling Data Requirements .....	6
	5.4 Substation Equipment Specifications .....	6
	5.5 Specific Scope of Work for the Legal Owner of a Transmission Facility .....	7
6	TRANSMISSION SYSTEM OPERATING CHARACTERISTICS.....	8
	6.1 Short Circuit Current Levels.....	8
	6.2 Voltage Levels .....	10
	6.3 Insulation Levels.....	10
	6.4 Remedial Action Scheme (RAS).....	11
7	APPENDICES .....	12
	7.1 Area Transmission System – Existing with Proposed Development Area .....	12
	7.2 Single Line Drawing.....	13
	7.2.1 Single Line Drawing – Existing North Lethbridge 370S Substation .....	13
	7.2.2 Single Line Drawing – North Lethbridge 370S Substation – Proposed.....	14
	7.3 SCADA Requirements.....	15
	7.4 Static Data Requirements.....	16

## 1 PURPOSE

(1) The purpose of this document (the “Functional Specification”) is to set out the technical specifications, requirements and approved variances related to the design, construction, development and commissioning of certain new or modified facilities (the “Project”) that have been proposed for or are related to a physical facilities connection with the Alberta **interconnected electric system** (AIES) (the Purpose). This Functional Specification is issued by the Alberta Electric System Operator (AESO) to:

(i) AltaLink Management Ltd. In its capacity as general partner of AltaLink, L.P., (AltaLink), as the **legal owner** of a **transmission facility** described in the Functional Specification.

(2) This Functional Specification is issued for the Purpose only. The **legal owner** of a **transmission facility** must comply with the Functional Specification provisions.

(3) The AESO is not responsible for any facilities designed by or for any third party, or installed on a third party’s behalf, to accomplish the connection of the Project facilities.

(4) This Functional Specification includes:

- (i) certain specific engineering, technical and functional requirements for the Project;
- (ii) the requirements to comply with **ISO rules**, including Operating Policies & Procedures (OPPs), **reliability standards**, technical standards, and **ISO tariff** provisions (collectively called the “Authoritative Documents”);
- (iii) the electrical system environment in which the connecting facilities must be designed and operated; and
- (iv) any approved variances from requirements set out in any applicable AESO Authoritative Documents.

## 2 INTERPRETATION AND VARIANCES

(1) Subject to Section 2(2), any revision or variance to any of the Functional Specification provisions by the parties named in Section 1(1) is prohibited.

(2) Any party named in Section 1(1) may make application, jointly or individually, in writing to the AESO requesting a variance to this Functional Specification, and the AESO may in writing approve of the variance after the AESO has completed an analysis of the implications to the AIES with respect to the requested variance.

(3) Words or phrases appearing in bold have the meanings set out in the AESO *Consolidated Authoritative Document Glossary*.

### 3 PROJECT OVERVIEW

This Project addresses the need to mitigate an overload on one of the 138 kV transmission lines under a transformer contingency in the AESO transmission planning area of Lethbridge (Area 54).

This Functional Specification includes the requirements for the following development:

- Modify the existing North Lethbridge 370S substation by adding one 138 kV circuit breaker.
- Add or modify associated equipment as required for the above transmission development.

The anticipated in-service date (ISD) for this Project is Q3, 2022.

### 4 FORECAST OF FUTURE DEVELOPMENT IN THE PROJECT AREA

Proposed long term developments in the Lethbridge (Area 54) are described in the AESO 2020 Long-term Transmission Plan. Please refer to the AESO's website ([www.aeso.ca](http://www.aeso.ca)) for more details of the long term transmission developments in the area.

### 5 SCOPE OF WORK

#### 5.1 General

The **legal owner** of a **transmission facility** must:

- (1) complete all engineering, design, land or land-use acquisition, siting, public consultation, applicable regulatory approvals and permits, material procurement, construction, commissioning, and associated permitting requirements for the Project facilities.
- (2) coordinate with each other, as required, on all Project facility design details, including protection and control, grounding, insulation, **point of connection**, and site layout with proper consideration of maintenance coordination.
- (3) develop joint operating procedures and any connection agreements, as required, such that all connecting **transmission facilities** will operate safely and reliably.
- (4) deliver to the AESO all final design and as-built Project facility information and records in the format and content required by the AESO, to enable the AESO to update and maintain its transmission technical records and system models.
- (5) submit the Project information and records referred to in subsection (4) above, under the professional stamp and signature of a registered professional engineer in Alberta who assumes responsibility for the preparation and accuracy of the content of the information and records.
- (6) mutually agree on each party's roles and responsibilities regarding inspection of all facilities of the Project prior to energization of the facilities.
- (7) ensure prior to energization of any or all of their respective Project facilities, that the facilities to be energized have been inspected by qualified personnel, so that the facilities are declared to be:
  - (a) safe for operation; and
  - (b) in compliance with this Functional Specification and any Authoritative Documents for which the Project must comply.

(8) Not energize any Project facilities until an energization authorization has been issued by the AESO in accordance with the **ISO rules**.

## 5.2 Compliance with AESO Authoritative Documents

Any party named in Section 1(1) must comply with the Authoritative Documents provisions which are applicable to the Project and which must be satisfied and incorporated into the design, construction, commissioning and operation of the connecting facilities and other connection Project work, including but not limited to these provisions contained herein:

- AESO Operating Policies and Procedures
- Alberta Reliability Standards
- AESO Measurement System Standard Rev. 1 (dated September 18, 2007) <sup>1</sup>
- **ISO rules** including:
  - Section 502.3, *Interconnected Electric System Protection Requirements* (effective September 1, 2018)<sup>2</sup>;
  - Section 502.4, *Automated Dispatch and Messaging System and Voice Communication Systems Requirements* (effective March 27, 2015);
  - Section 502.8, *SCADA Technical and Operating Requirements* (effective September 1, 2018)<sup>2</sup>;

## 5.3 Modelling Data Requirements

All modelling data shall be provided as per the Information Document ID# 2010-001R Facility Modelling Data (issued on December 20, 2018), which relates to Section 502.15 of the **ISO rules**, *Reporting Facility Modelling*.

## 5.4 Substation Equipment Specifications

All new substation equipment<sup>3</sup> must meet the following minimum specifications:

- Temperature rating of -40°C for all outdoor equipment.
- Equipment maximum and minimum continuous voltage ratings as indicated in Table 4.
- Minimum continuous equipment current ratings as indicated in Table 1.
- Equipment maximum fault duty: 31.5 kA for 138 kV.

---

<sup>1</sup> The AESO considers this standard to remain in effect notwithstanding the statement in clause 1.5 of this standard. Efforts to revise the standard are currently underway.

<sup>2</sup> The AESO has published these new or amended ISO rules on AESO's website. Future facilities that are not yet operational will be required to comply with the ISO rules as of the effective date.

<sup>3</sup> Equipment includes such items as the power transformer, circuit breaker, capacitor bank, shunt reactor, high voltage current transformer, potential transformer, bus work, air break, and switchgear.

**Table 1: Minimum Continuous Equipment Current Ratings (A)**

Component <sup>note 5</sup>	138 kV
Main Bus <sup>Note 1</sup>	1200
Cross Bus <sup>Note 2,3</sup>	600
Equipment or line terminal <sup>Note 4</sup>	600

Notes for Table 1:

- Note 1: Main bus includes all sections of ring bus scheme or single bus of simple bus or breaker and a half scheme except the portion of the bus connecting to a transformer.
- Note 2: Cross bus includes diameter sections of breaker and a half or breaker and a third schemes.
- Note 3: Cross bus can have higher minimum current rating based on bus configuration and equipment connectivity
- Note 4: Line terminal includes all equipment and conductor from the transmission line to the line breakers.
- Note 5: Current rating of the equipment below 69 kV within the substation shall be determined by the **legal owner** of a **transmission facility**.

## 5.5 Specific Scope of Work for the Legal Owner of a Transmission Facility

### (1) General Requirements

- Ensure project safety is appropriately managed from design through energization.
- Undertake all required grounding studies, testing and mitigation, as required, for electrical safety and any mitigation for electrical effects on communication systems.
- All site preparation, fencing, foundations, grounding, support structures, termination structures, duct work, cabling, bus work, station service, control building, protection, controls, SCADA equipment, etc., as required.
- Any lines from one bus terminal to remote bus terminal shall not have any terminal equipment that causes a derate of the minimum line capacity specified by the AESO.

### (2) Existing North Lethbridge 370S substation – See Appendix 7.2

#### Substation Major Equipment

- Add one (1) 138 kV circuit breaker.
- Replace the existing motor operated disconnect (MOD) switch 370S3 by a new MOD.

#### Protection and Control Requirements

- Complete system protection coordination studies as required to establish settings appropriate for the facility additions and AIES operations.
- Install all the required protection and control equipment to accommodate the new facilities addition.
- Review, modify and/or upgrade the existing protections as required to accommodate the new connection and configuration.



## SCADA Requirements

- Establish communications interface point such that SCADA data can be transmitted back to the AESO's System Coordination Center (SCC) and Backup Coordination Centre (BUCC).
- All new Remote Terminal Units (RTU) shall have Global Positioning System (GPS) for time synchronization.
- Implement control center data mapping and verification of SCADA information for the proposed transmission facility additions and modifications, and any associated changes required at other area substations as per Section 502.8 of the **ISO rules**. A complete listing of energy data requirements can be found in Appendices 7.3 and 7.4 of this document.

## Telecommunication Requirements

- Install new or modify/upgrade the existing communication system as required and establish appropriate communication interface such that tele-protection, SCADA, operational voice, operational data and mobile radio requirements are met.

## 6 TRANSMISSION SYSTEM OPERATING CHARACTERISTICS

The **legal owner** of a **transmission facility** must ensure all facilities are capable of operating in the following electrical environment.

### 6.1 Short Circuit Current Levels

(1) The short circuit current levels set out in Tables 2 and 3 have been derived by the AESO based on information provided by the **legal owner** of a **transmission facility**, any connecting **generating units**, and adjacent operating areas. Available fault current levels will continue to increase as generation, transmission, and system inter-ties are added to the AIES. The **legal owner** of a **transmission facility** must continue to review the fault levels and their equipment ratings for adequacy.

(2) Any future equipment upgrades or protection system setting changes required due to increasing fault levels are the responsibility of the **legal owner** of a **transmission facility**, as applicable.

(3) The following assumptions were incorporated into the AESO short circuit current models:

- (i) All expected Alberta generation is dispatched.
- (ii) All transmission elements are in service.
- (iii) The proposed Project facility is connected as per this document.
- (iv)  $V_{base} = V_{bus}$ ,  $MVA_{base} = 100$

**Table 2: Summary of Short-Circuit Current Levels – 2021 Pre/Post-Project**

Substation	Base Voltage (kV)	Pre-Fault Voltage (kV)	3-Φ Fault (kA)	Positive Sequence Thevenin Source Impedance (R1+jX1) (pu)	1-Φ Fault (kA)	Zero Sequence Thevenin Source Impedance (R0+jX0) (pu)
North Lethbridge 370S	240	241.2	11.9	0.004390+j0.021826	9.9	0.006794+j0.035180
North Lethbridge 370S	138	144.1	13.3	0.008392+j0.034947	11.3	0.009100+j0.054640
Chinook 181S	138	142.7	8.4	0.017395+j0.053218	6.1	0.026504+j0.116394
Coalbanks 111S	138	142.8	10.4	0.012915+j0.043741	8.0	0.018930+j0.084041
Uplands 241S	138	143.8	11.2	0.009802+j0.041324	8.8	0.015049+j0.076324
Macdonald 146S	138	143.6	11.2	0.009940+j0.041251	8.8	0.015072+j0.076109
Windy Flats 138S	240	240.9	12.3	0.003298+j0.020831	9.1	0.010696+j0.042145
Picture Butte 120S	230	229.1	4.5	0.004481+j0.060695	4.0	0.009708+j0.082010
Travers 554S	240	246.6	8.5	0.005548+j0.032497	8.7	0.002753+j0.030524

**Table 3: Summary of Short-Circuit Current Levels – 2031 Post-Project**

Substation	Base Voltage (kV)	Pre-Fault Voltage (kV)	3-Φ Fault (kA)	Positive Sequence Thevenin Source Impedance (R1+jX1) (pu)	1-Φ Fault (kA)	Zero Sequence Thevenin Source Impedance (R0+jX0) (pu)
North Lethbridge 370S	240	247.3	13.3	0.002876+j0.019715	12.4	0.003659+j0.023899
North Lethbridge 370S	138	140.6	14.0	0.005039+j0.032212	12.8	0.005122+j0.041983
Chinook 181S	138	140.5	8.6	0.014055+j0.051414	6.4	0.023377+j0.105972
Coalbanks 111S	138	140.3	10.6	0.009485+j0.041673	8.5	0.015522+j0.072784
Uplands 241S	138	140.5	11.6	0.006328+j0.038762	9.5	0.011159+j0.063904
Macdonald 146S	138	140.5	11.6	0.006452+j0.038790	9.5	0.011270+j0.063950
Windy Flats 138S	240	247.9	15.0	0.002122+j0.017393	11.7	0.007771+j0.031528
Picture Butte 120S	230	231.8	4.6	0.003316+j0.058776	4.3	0.006194+j0.069857
Travers 554S	240	246.3	8.9	0.004448+j0.030871	9.1	0.002714+j0.029101

## 6.2 Voltage Levels

Table 4 provides the normal planned operating voltage range in the area of the proposed facility.

**Table 4: Planned Operating Range**

Substation Name and Number	Nominal Voltage (kV)	Emergency Minimum Voltage (kV)	Desired Normal Minimum Voltage (kV)	Desired Normal Maximum Voltage (kV)	Emergency Maximum Voltage (kV)
North Lethbridge 370S	138	124	135	145	150

Notes:

1. The Desired Normal Operating Minimum and Desired Normal Operating Maximum are generally associated with Category A events and system normal.
2. The Emergency Minimum Voltage and Emergency Maximum Voltage are generally associated with Category B and C events and system abnormal.
3. The facilities must be capable of continuous operation at voltages up to and including the Emergency Maximum Voltage.

## 6.3 Insulation Levels

(1) Table 5 provides the minimum required basic insulation levels for the **transmission facilities**. Station equipment with lower insulation levels may be used provided that protection and coordination can be maintained with judicious insulation design and use of appropriate surge arresting equipment.

**Table 5: Basic Insulation Levels (kV)**

Nominal Voltage Classification (kV rms)	138
Station Post Insulators and Airbreaks	550
Circuit Breakers	650
Current and Potential Transformers	650
Transformer Windings (Protected by Surge Arresters)	550

## 6.4 Remedial Action Scheme (RAS)

The Engineering Study Report (ESR) for this Project has indicated that no new or modification to existing/planned RAS(s) or System Control Procedures (SCPs) were identified for this Project, under Category B contingency conditions, based on assumptions used in the study.

Prior to the ISD of the Project, additional operations planning studies will be performed to determine and/or confirm the required mitigation measures, RAS(s), or procedures, by taking into account other connection and system projects, as appropriate. System conditions under additional contingency categories will also be assessed as part of operations planning studies. This will ensure that appropriate mitigation will be in place prior to the ISD of the Project. The AESO will consult with the **legal owner** of a **transmission facility** before specifying revised and/or new mitigation measures.

## 7 APPENDICES

### 7.1 Area Transmission System – Existing with Proposed Development Area

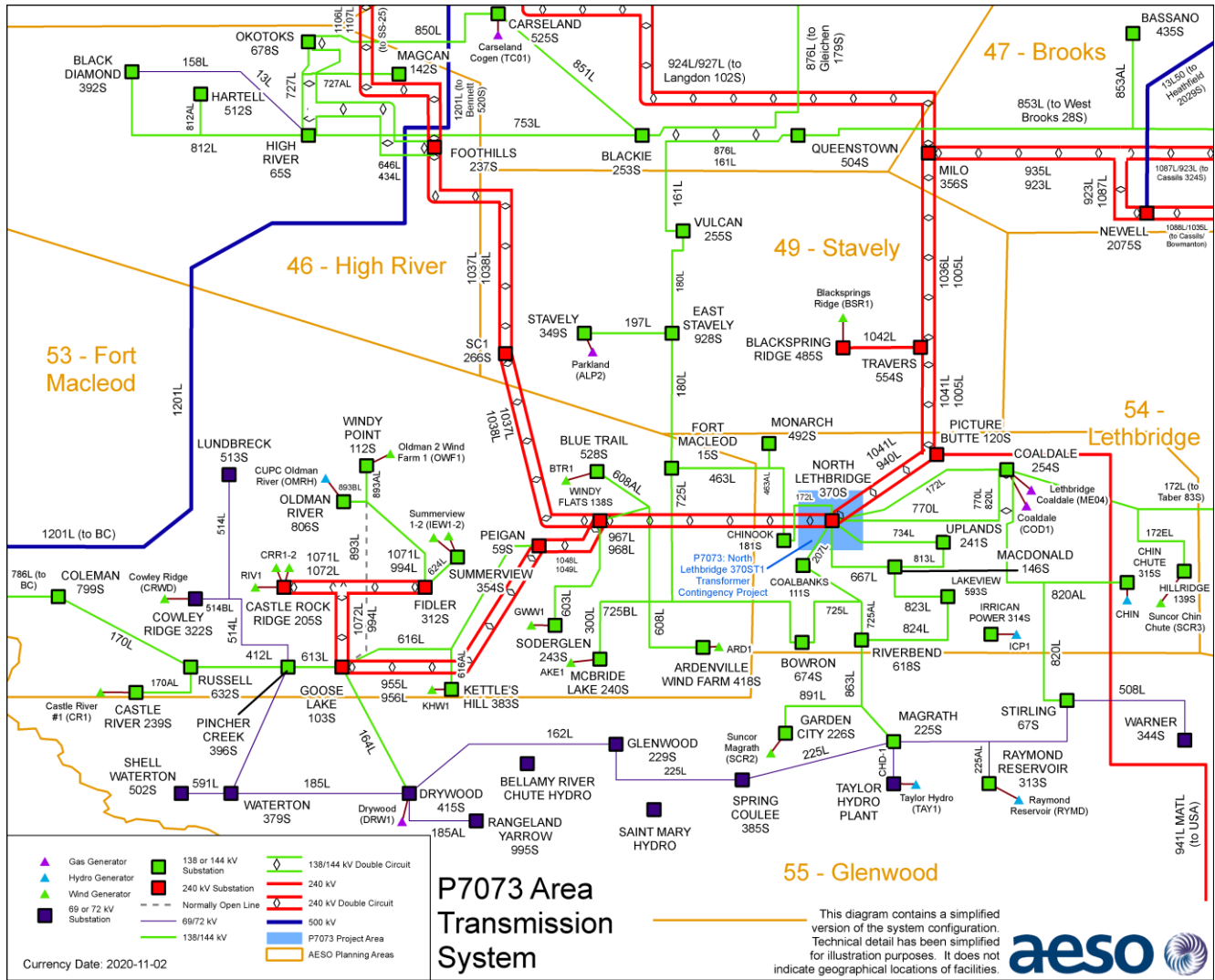

## 7.2 Single Line Drawing

### 7.2.1 Single Line Drawing – Existing North Lethbridge 370S Substation

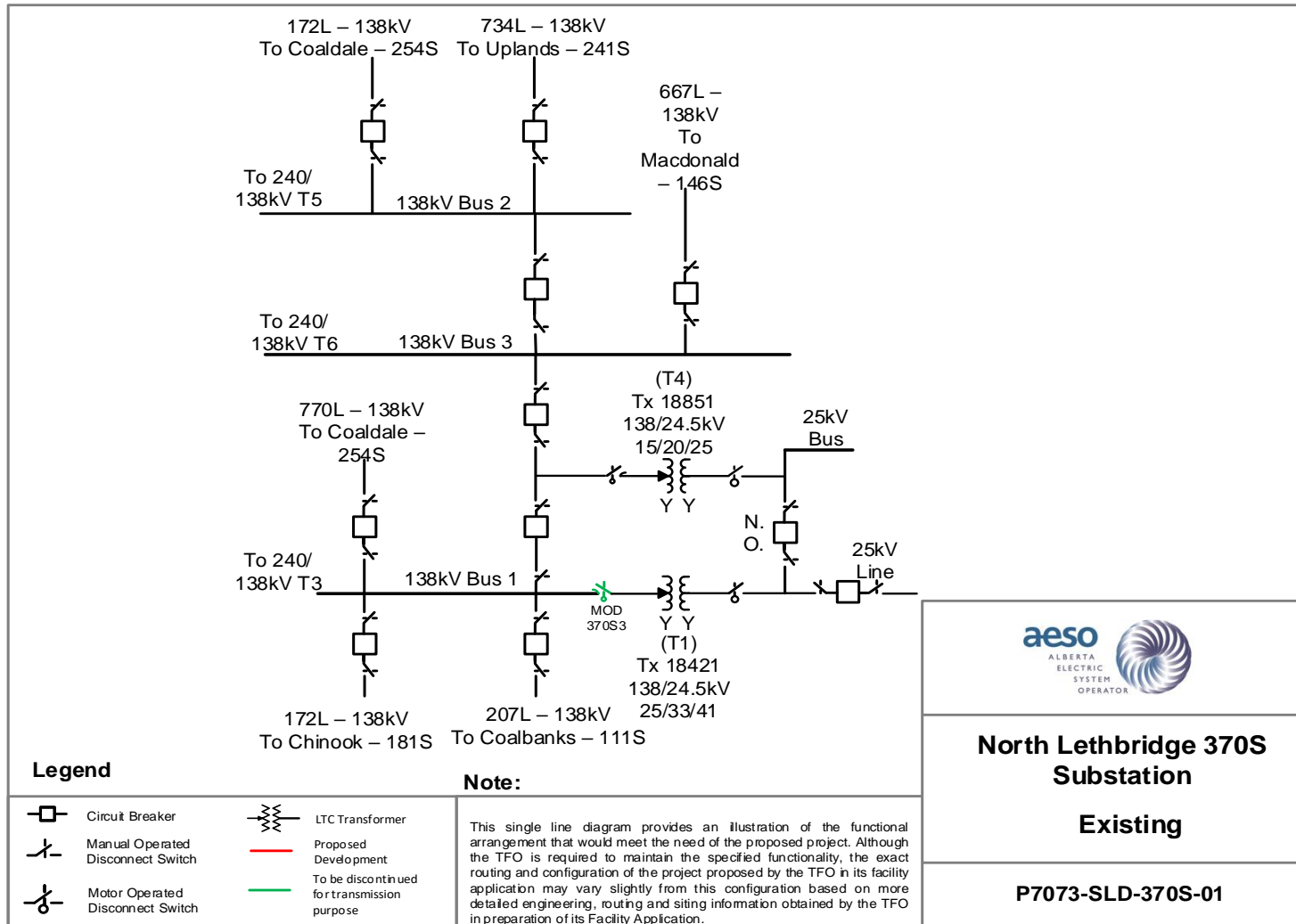

### 7.2.2 Single Line Drawing – North Lethbridge 370S Substation – Proposed

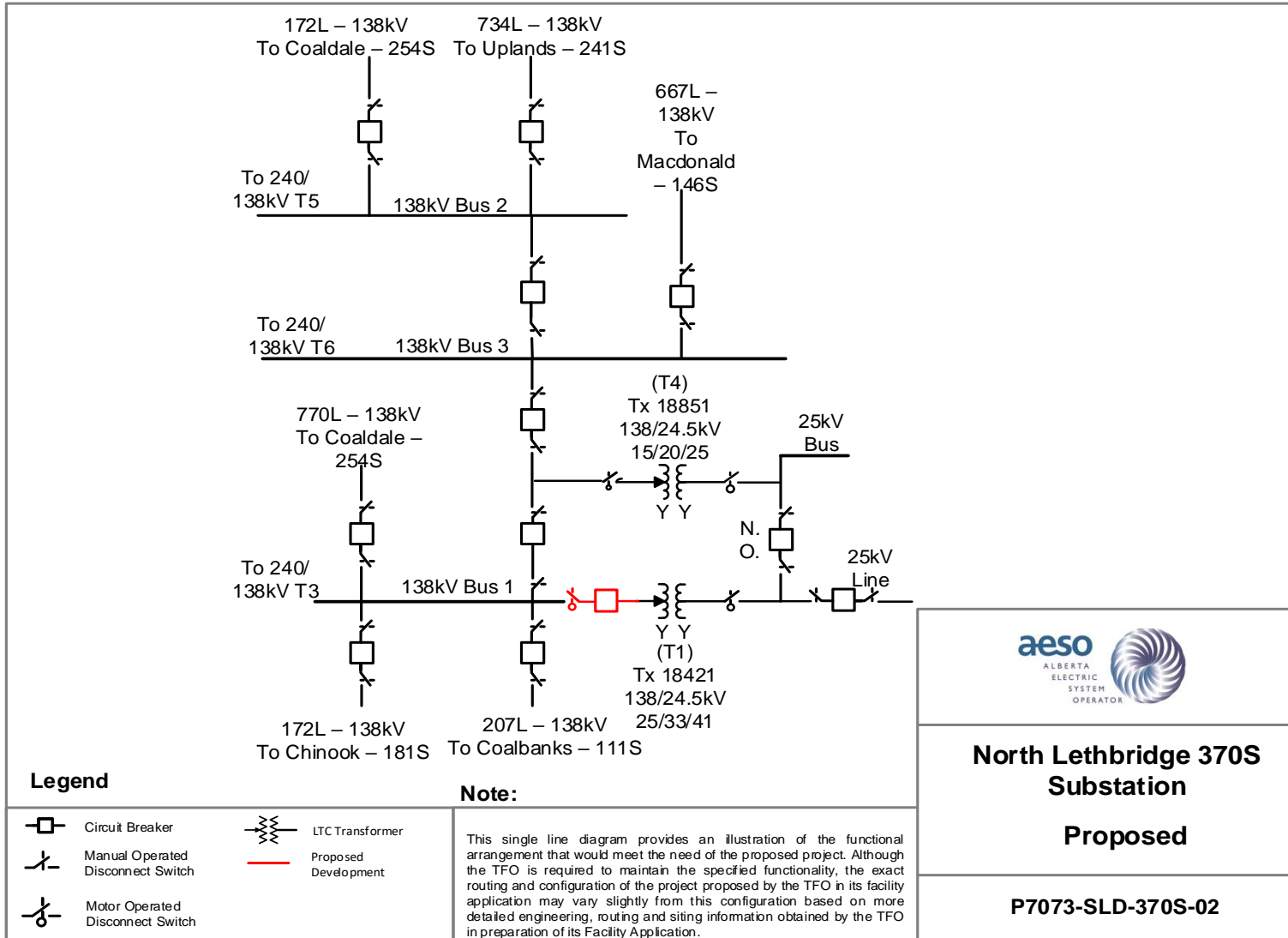

### 7.3 SCADA Requirements

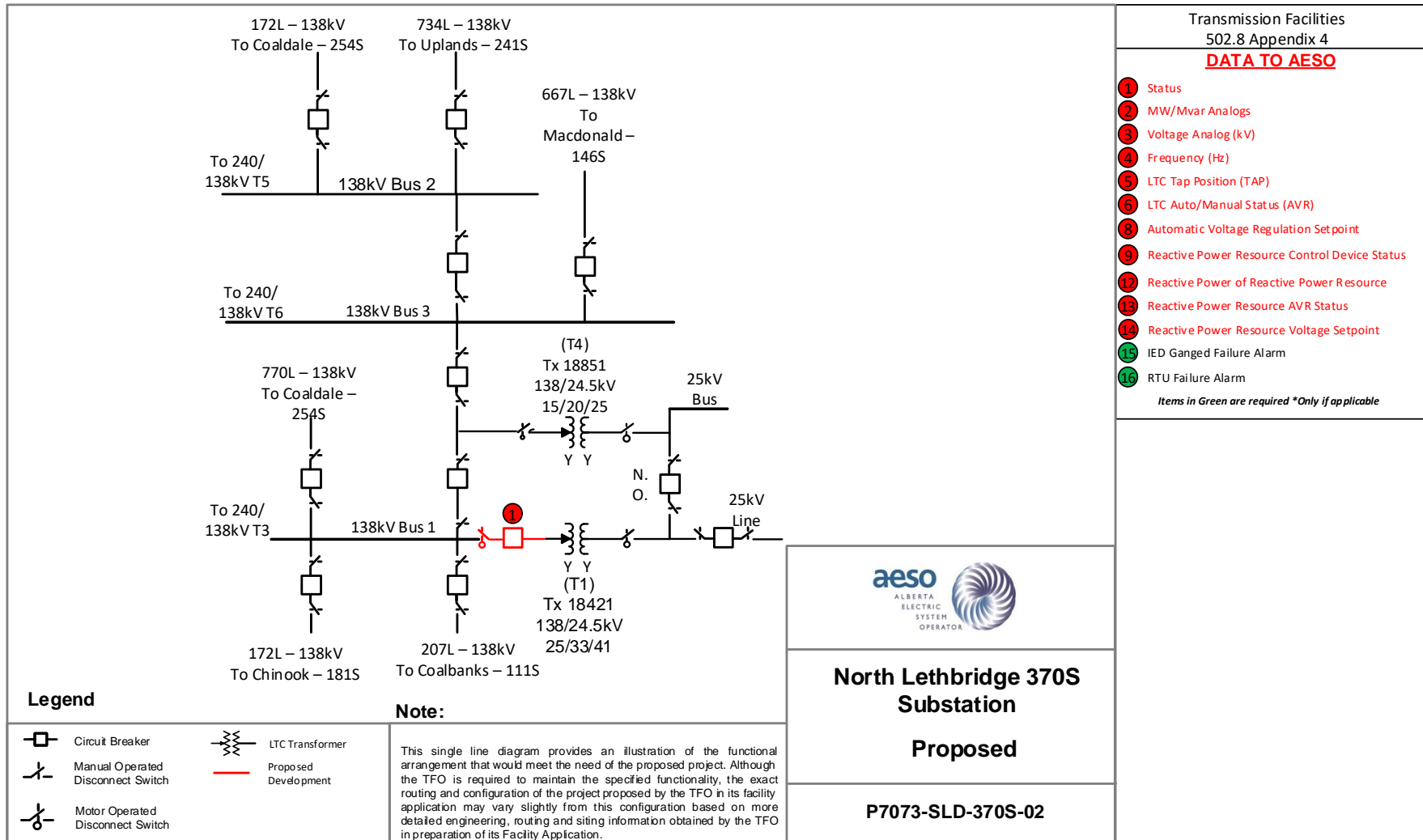





### 7.4 Static Data Requirements

Facility/Location	Device	Element	Indication	Max Latency	Notes
<b>AltaLink Ltd</b>	138kV Circuit Breaker	CB1 associated with the high side of T1	Status	15s	
<b>370S North Lethbridge</b>					
<b>From AESO</b>					
<b>Note</b>	<b>1. MW and MVAR SCADA data shall be gathered independently of the revenue metering data</b>				
	<b>2. An external GPS based signal shall be utilized to provide 1ms time stamped event accuracy</b>				
	<b>3. Additional SCADA measurements may be required for resources to provide ancillary services</b>				